

| Parts List | | | |
|------------|-----|-------------|-------------------------------|
| ITEM | QTY | PART NUMBER | DESCRIPTION |
| 1 | 1 | LSTM075H | 3/4" NPT MINI T-STRAINER HEAD |
| 2 | 1 | LST530 | 1/2" LST SCREEN - 30 MESH |
| 3 | 1 | LSTM050G | MINI T-STRAINER GASKET |
| 4 | 1 | LSTM050BC | MINI T-STRAINER CLEAR BOWL |

***NOTE:**
ADDITIONAL CLEARANCE REQ'D
FOR SCREEN REMOVAL: 2 3/4"

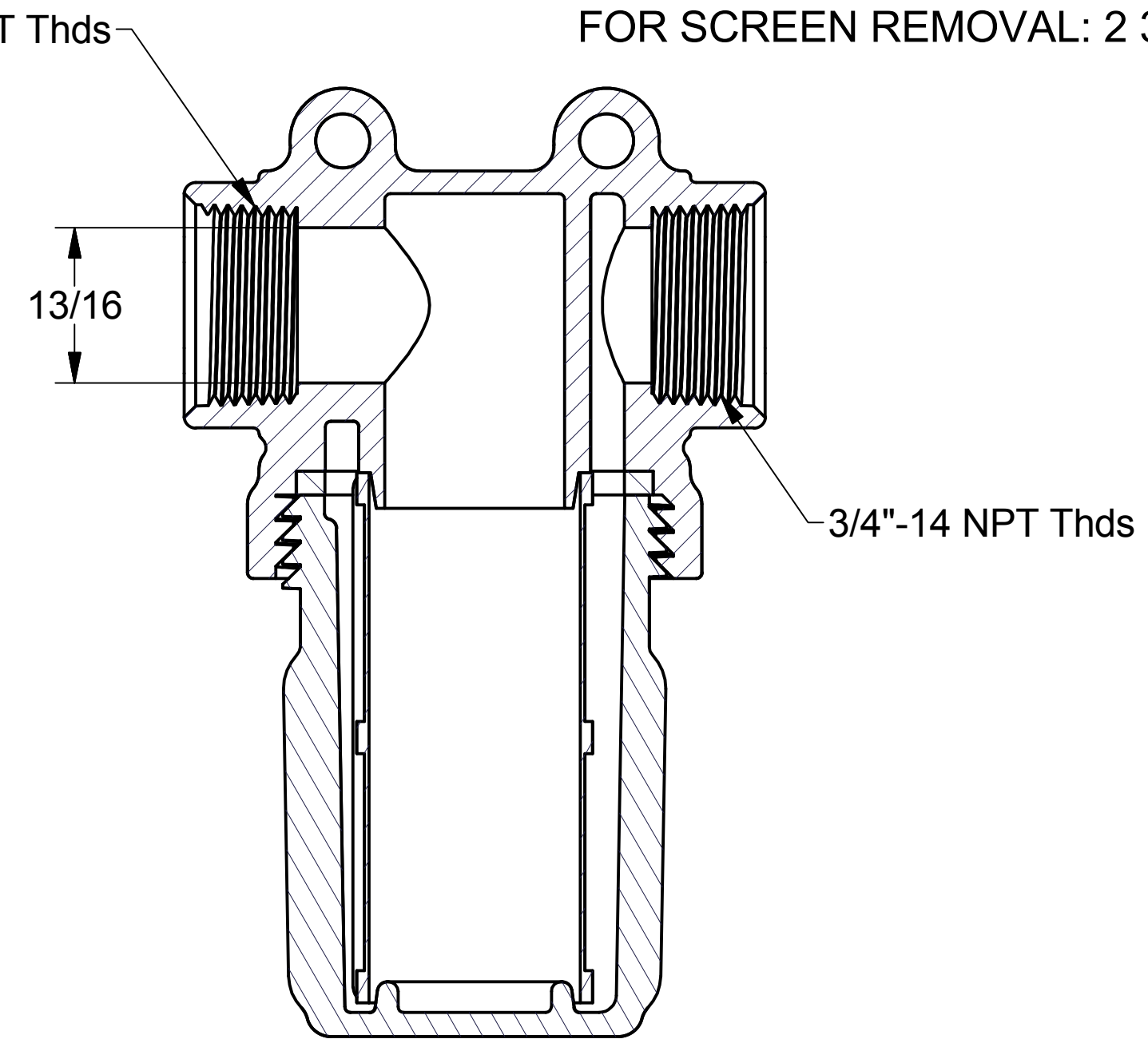

SECTION A-A
SCALE 1.25

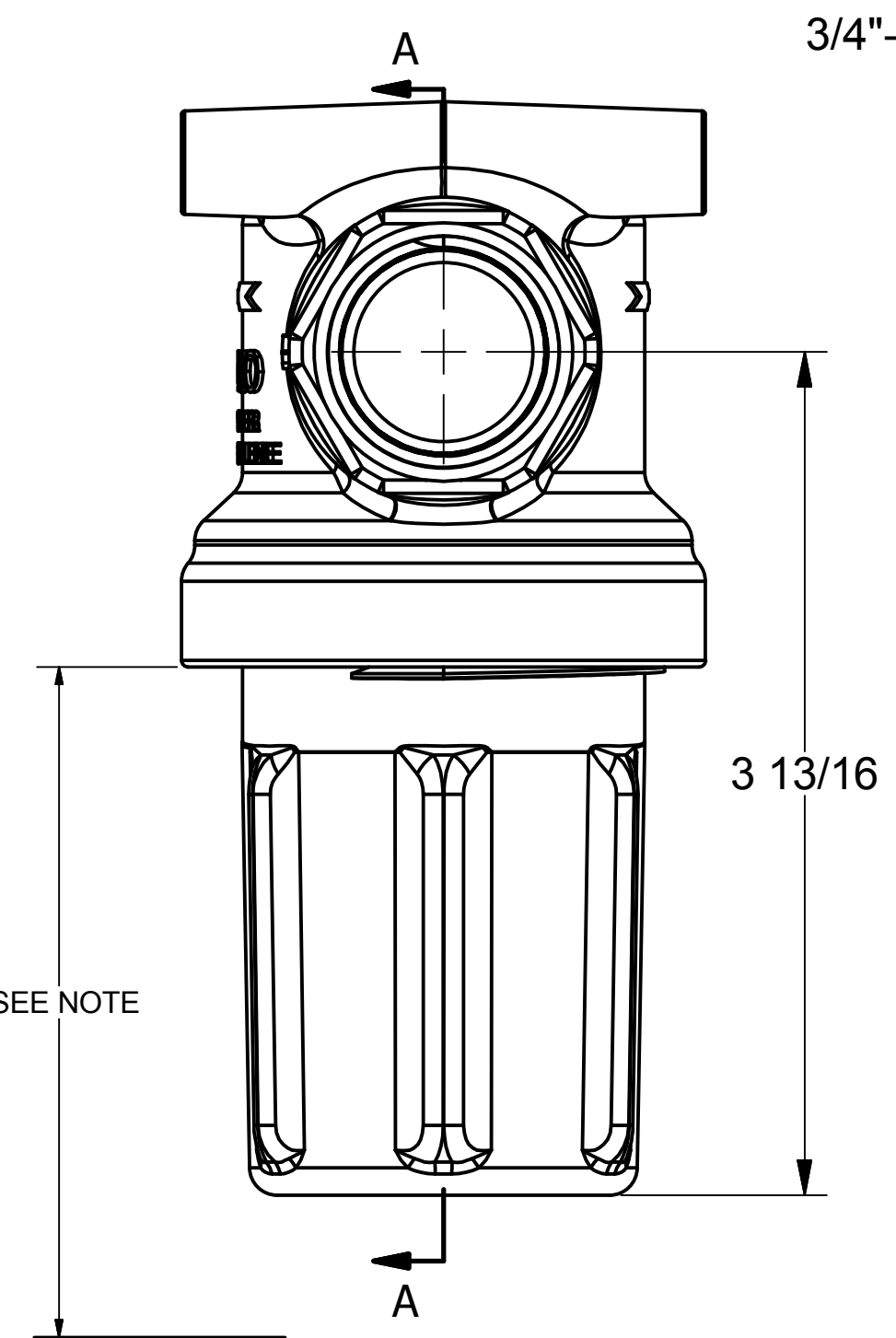
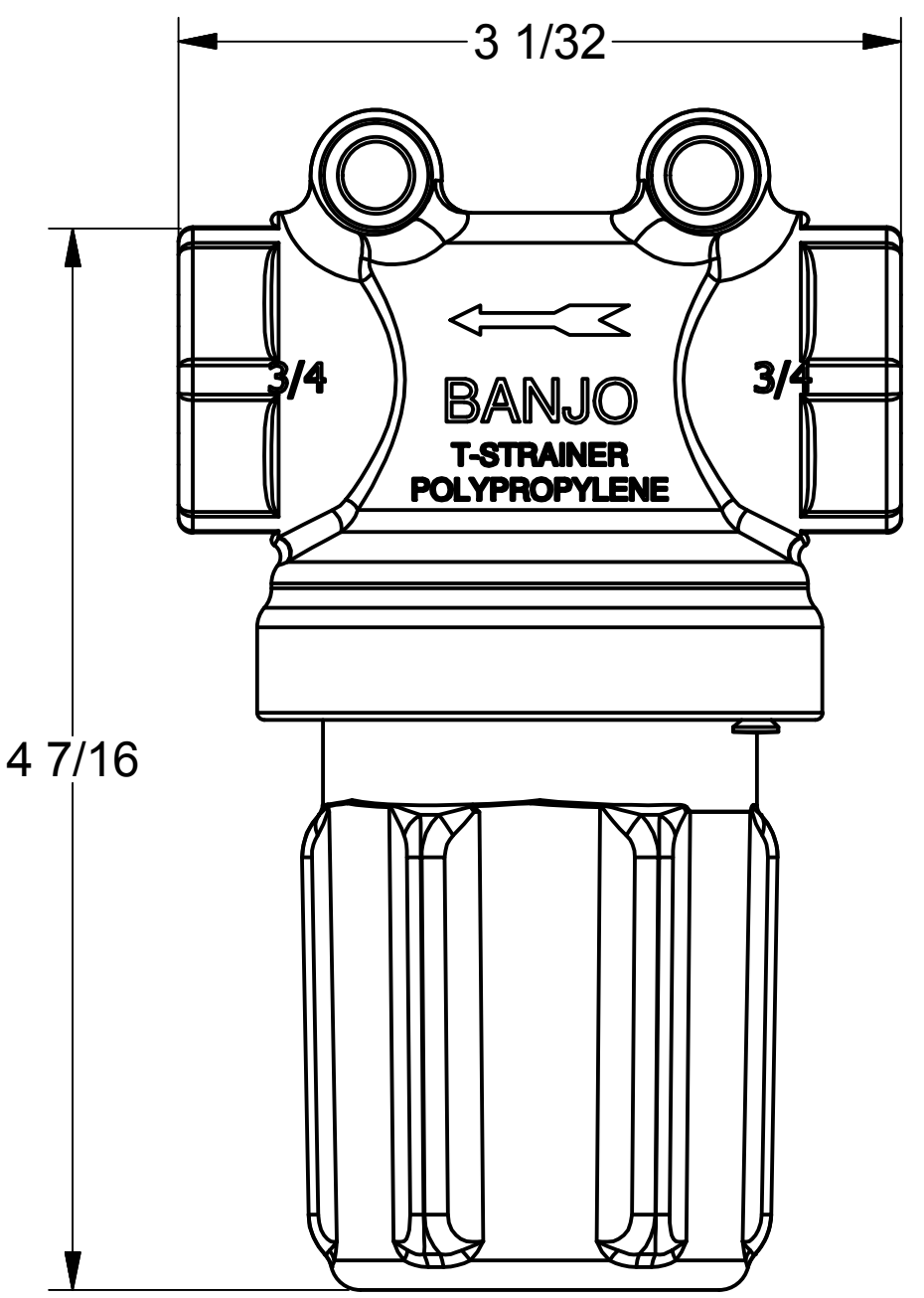
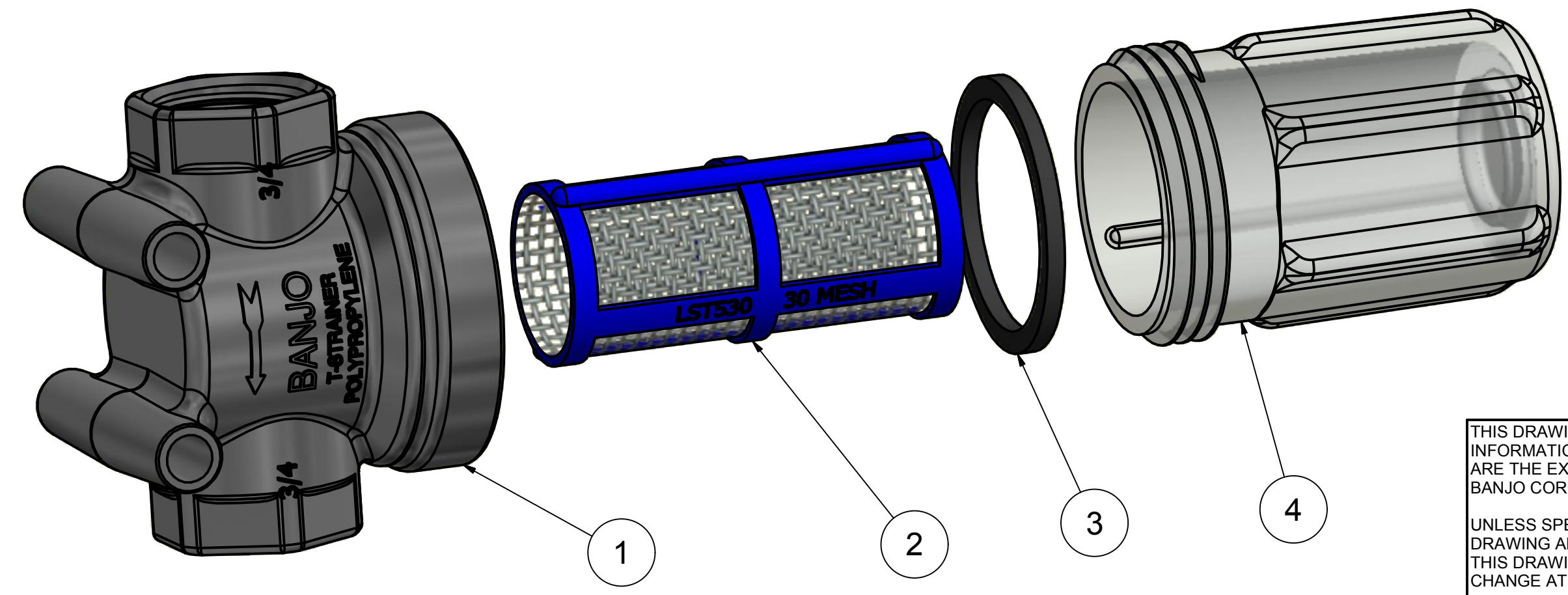

THIS DRAWING AND ALL INFORMATION CONTAINED THEREON ARE THE EXCLUSIVE PROPERTY OF BANJO CORPORATION.
UNLESS SPECIFICALLY NOTED, THIS DRAWING AND ITEMS SHOWN ON THIS DRAWING ARE SUBJECT TO CHANGE AT ANY TIME.

BANJO CORPORATION
150 BANJO DRIVE, CRAWFORDSVILLE, IN 47933
WEB SITE: WWW.BANJOCORP.COM
E-MAIL: BANJOSALES@IDEXCORP.COM

DESCRIPTION: 3/4" MINI T-STRAINER Clear Bowl, 30 Mesh
PART NUMBER: LSTM075-30C